



Laser Diode ZBD-LD-639-2100M-F91

ZBD-LD-639-2100M-F91 is a multimode laser diode with 2.1W CW output power at 639nm. Its beam pattern is linear with $9^\circ \times 1^\circ$ ($\theta_{//} \cdot \theta_{\perp}$). It is supplied in a 9mm floating mounted TO-CAN package. The laser diode is suitable for opto-electronic applications.

■ Absolute Maximum Ratings

Parameter	Symbol	Conditions	Value	Unit
Output Optical Power	P_o	CW	2.1	W
Pulse Optical Output Power	$P_o(\text{Pulse})$	$I_{op}(\text{Pulse})=3.3\text{A}$, duty=30%, $f=120\text{Hz}$	2.5	W
LD reverse voltage	$V_{R(LD)}$	-	2	V
Storage Temperature	T_{stg}	-	-40~+85	$^\circ\text{C}$
Operating Case Temperature	T_c	-	-10~+55	$^\circ\text{C}$
Lead soldering temperature (10 sec.)	T_{std}	-	260	$^\circ\text{C}$

■ Initial Electrical/Optical Characteristics ($T_c=25^\circ\text{C}$)

Parameter		Symbol	Condition	Min	Typ.	Max	Unit
Threshold Current		I_{th}	CW	-	550	-	mA
Operating current (CW)		I_{op}	$P_o=2.4\text{W}$	-	2.25	2.95	A
Operating Voltage		V_{op}		-	2.25	-	V
Peak Wavelength		λ_p		635	639	644	nm
Beam Divergence*	Parallel	$\theta_{//}$		-	9	-	$^\circ$
	Perpendicular	θ_{\perp}		-	1	-	$^\circ$

* Full angle at $1/e^2$ from peak intensity



■ Beam Pattern



■ Outline Dimension (Unit: mm)

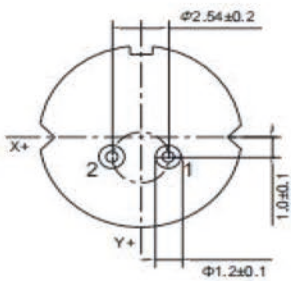
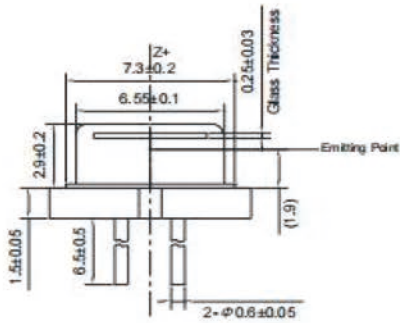
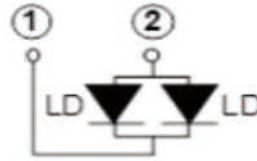
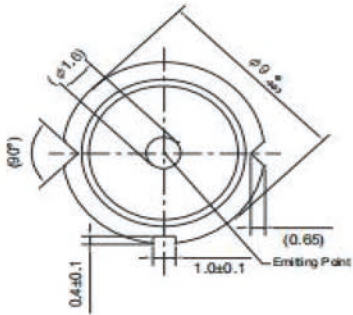

Unit: mm



■ Cautions

1. Laser light can damage the human eye and skin. Do not expose the eye and skin to any laser light directly or through optical lenses. Focused laser beam through optical instruments will increase the chance of eye hazard.
2. The laser needs a stable driver to avoid surges. The instantaneous reverse current and reverse voltage should not exceed the absolute maximum ratings, otherwise it will damage the laser diode.
3. Semiconductor lasers are sensitive to temperature, working at high temperatures will reduce the photoelectric conversion efficiency and accelerate the aging of laser diode. It should be used under adequate heat dissipation or cooling conditions.
4. The laser should be used at the rated current and rated power, the output power is too high will accelerate the aging of laser diode.
5. Semiconductor lasers are electrostatic sensitive devices, anti-static measures should be taken during storage and transportation.
6. Lasers should be stored or work in a dry, ventilated environment to prevent damage to the laser from condensation.
7. The light emitting surface (cavity surface) is the key parts of the laser diode, any handling to damage the cavity surface should be strictly prohibited. It should be ensured that the laser diode is not contaminated, and damaged in mechanical.

